

Assembly Instructions

Note: Do not tighten Fasteners until all bolts are started hand tight, all nuts are on ground side, or to center of wheelbarrow.

- 1) Insert Carriage "Bolt A" (2) into bottom front retainers.
- 2) Insert Carriage "Bolt B" (2) into bottom Rear retainers, load wedges & handles over bolts, load bottom supports (Short & long) over bolts, Load legs over bolts, Fasten with Flange "Nut B"
- 3) Insert Carriage "Bolt C" (2) into Retainer, Load Tub Support over bolt. Fasten with Flange "Nut B"
- 4) Insert "Bolt E" (4) thru leg and leg support. Fasten with Washer and Locking "Nut A"
- 5) Insert "Bolt D" (4) thru Foot and Leg. Fasten with Washer and Locking "Nut A"
- 6) Insert "Bolt F" (4) thru Nose Piece and Handle. Fasten with Washer and Locking "Nut A"
- 7) Insert "Bolt G" (2) thru Tub Support, Handle, and Axle Mount. Fasten with Washer and Locking "Nut A"
Bolt one Axle Mount (Dimple to outside) hold Tire between Handles, insert Axle, then Bolt other Axle Mount
- 8) Insert "Bolt F" (2) thru Handle, and Axle Mount. Fasten with Washer and Locking "Nut A"
- 9) Final tighten all fasteners

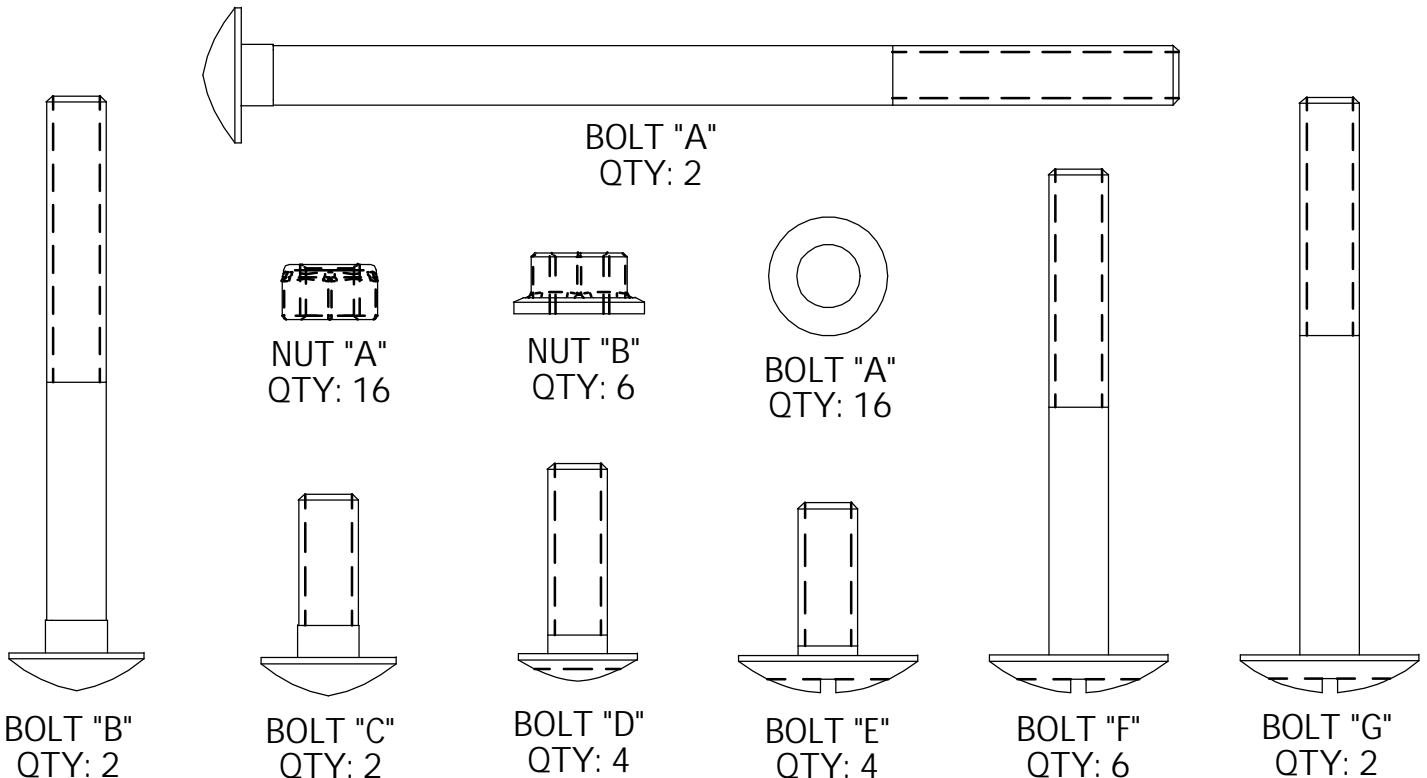

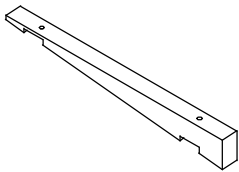
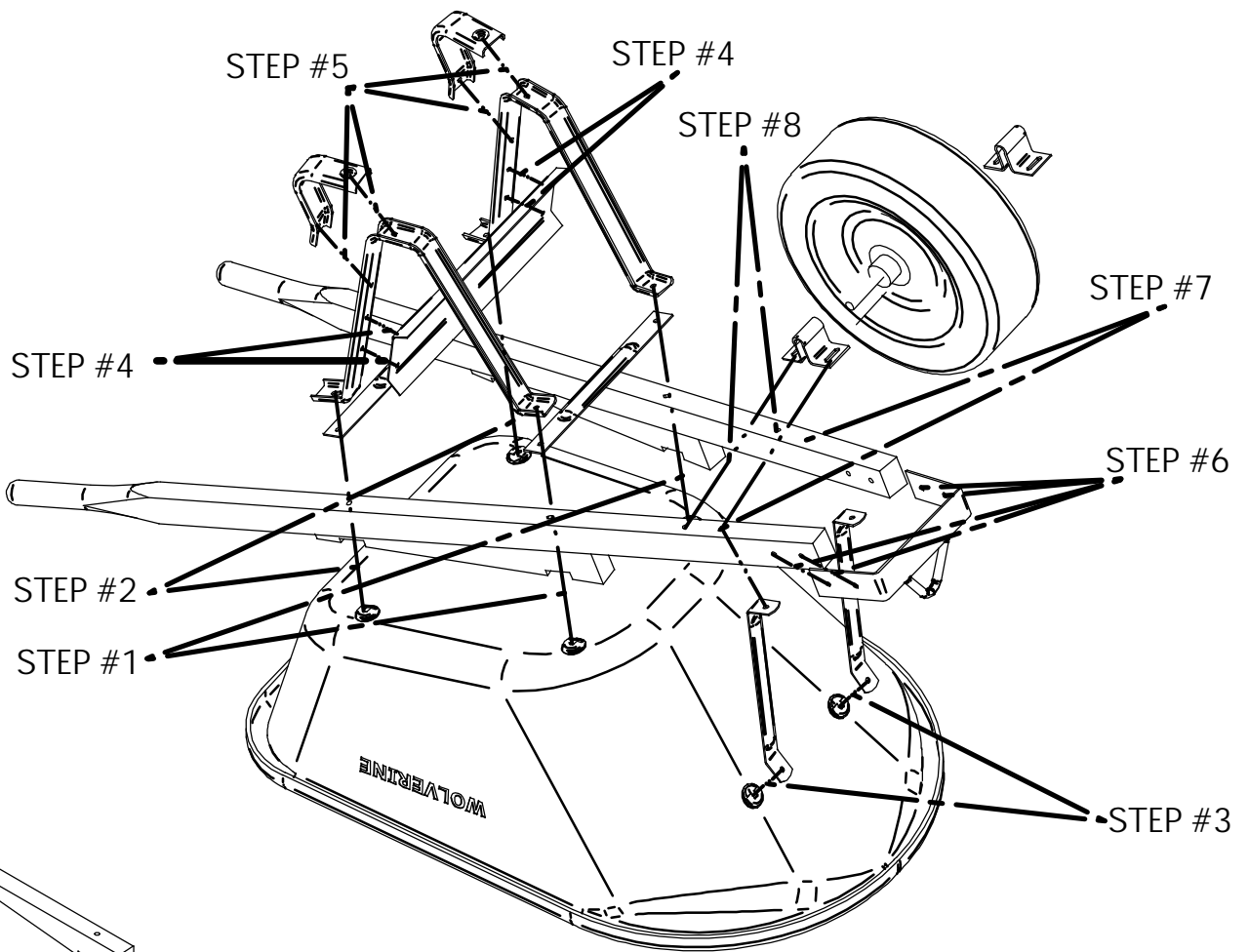

WEDGE
QTY: 2

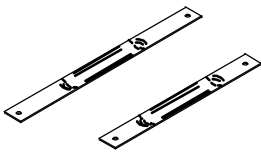

BOTTOM SUPPORTS
QTY: 1 LONG
QTY: 1 SHORT



TUB SUPPORT
QTY: 2

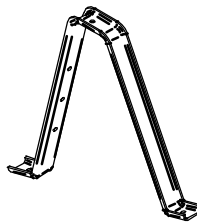

LEG
QTY: 2

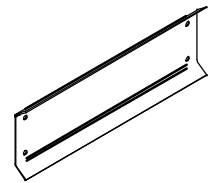

LEG SUPPORT
QTY: 1



FOOT
QTY: 2

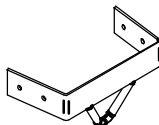

NOSE PIECE
QTY: 1



AXLE MOUNT
QTY: 2

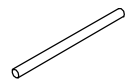

AXLE
QTY: 1



www.wolverinehandtools.com

Wolverine Products

494 East 64th Street
Holland, Michigan 49423
Phone: 1-800-787-3562

info@surelocecdging.com